

# Stereohype

graphic art and fashion boutique  
www.stereohype.com

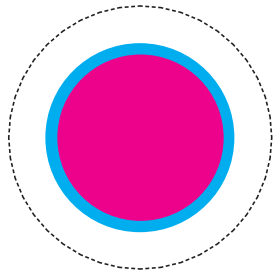

## Stereohype Button Badge Design Competition 2006

Deadline: Friday, 24th November, 2006

### NO ENTRY FEE!

After the huge success of our 2004 and 2005 design competitions we are now pleased to announce this year's 1" (25mm) 'stereohype button badge design competition 2006'. We look forward to receiving your submissions.

Please send us by email one to [a maximum of] three different badge designs per participant.

Please refer to the file specifications on page 3.

Eligible are entries by professional designers, artists, photographers and illustrators or by students in any of these areas.

Your artwork(s) will have to be created by yourself and should obviously not infringe any copyrights! Winners will give stereohype.com automatically a NON-exclusive licence to reproduce the winning artwork(s) on badges and stereohype-badge-related promotional materials such as postcards, etc.

By submitting your artwork(s) you agree on these terms and conditions. A shortlist will also be featured at stereohype.com crediting the artists and designers.

We will give winning artworks away as a free surprise badge with purchased stereohype T-shirts or sell them separately. Your badge design(s) might also be reprinted for promotional purposes featuring photos of your badge. Designers, artists and illustrators will - wherever possible - be appropriately credited. We would like to have one to [a maximum of] three artworks per person. Please bear in mind though, that we are aiming to give them away one at a time (although sets of 3 will be made available in a special packaging).

We can't wait to see your design(s)!

**GOOD LUCK!**

# Stereohype

graphic art and fashion boutique  
www.stereohype.com

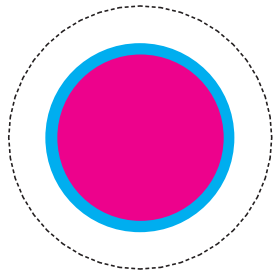

Stereohype will offer winners the following prizes within each category ('single badge designs' and 'sets of three');

## 1st prize:

\*\*\*

your personal mini profile/bio (with URL to your website) on stereohype.com with short descriptive text about your artwork(s).

\*\*\*

a total of ten free 1" badges per person for single entries or fifteen for sets of three with either your own design(s) or a badge selection of other designers (just let us know what you prefer).

\*\*\*

one free stereohype 'squirrel' OR 'orange squirrel' t-shirt.

\*\*\*

plus one free t-shirt of your choice (subject to availability).

## 2nd prize:

\*\*\*

your personal mini profile/bio (with URL to your website) on stereohype.com with short descriptive text about your artwork(s).

\*\*\*

a total of ten free 1" badges per person for single entries or fifteen for sets of three with either your own design(s) or a badge selection of other designers (just let us know what you prefer).

\*\*\*

one free stereohype 'squirrel' OR 'orange squirrel' t-shirt.

## 3rd prize:

\*\*\*

your personal mini profile/bio (with URL to your website) on stereohype.com with short descriptive text about your artwork(s).

\*\*\*

a total of ten free 1" badges per person for single entries or fifteen for sets of three with either your own design(s) or a badge selection of other designers (just let us know what you prefer).

## Judging panel:

A selection of international graphic designers.

Confirmed judges: (Please check our website for updates)

Agathe Jacquillat, [FL@33](mailto:FL@33), [flat33.com](http://flat33.com)

Elisabeth Lecourt, [elisabethlecourt.com](http://elisabethlecourt.com)

Richard Kirk, onepom, [onepom.com](http://onepom.com)

Tomi Vollauschek, [FL@33](mailto:FL@33), [flat33.com](http://flat33.com)

# Stereohype

graphic art and fashion boutique  
www.stereohype.com

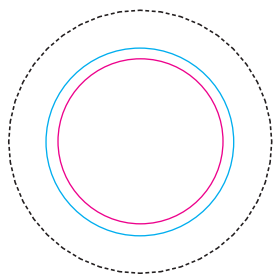
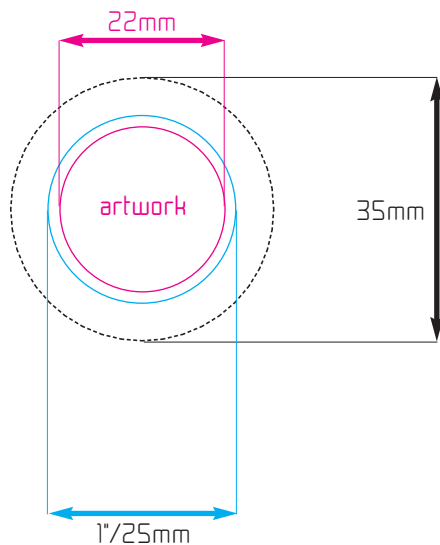
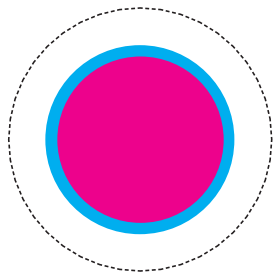

## Artwork guide ///

The magenta circle (22mm) shows recommended image area. The cyan circle (25mm) the actual badge size you should work in. Circles are there for guidance only and must not be included in your artwork. The black circle (35mm) is the cutting guide and must be shown on all artwork. Background colours should extend to cutting circle.

Please send your artwork(s) WITH a short bio AND artwork description (if applicable) (altogether approx. 250 words) via email to [submit@stereohype.com](mailto:submit@stereohype.com)

Accepted files:

### LO-RES PREVIEW:

PLEASE DO SEND US YOUR DESIGN(S) AS SEPARATE JPGs (150dpi, RGB) AND AS HI-RES FILE(S):

### HI-RES: colour designs in CMYK

vector graphics or hi-res files (300 dpi)  
\*.ai (illustrator 5-10) \*.fh8-11 \*.eps \*.tif \*.jpg \*.psd

### HI-RES: black/greyscale designs in B/W or GREYSCALE

vector graphics or hi-res scans (900-1200 dpi)  
\*.ai (illustrator 5-10) \*.fh8-11 \*.eps \*.bmp \*.tif \*.jpg \*.psd

Please ensure that ALL fonts are transformed to paths, embedded or submitted with your entry.